











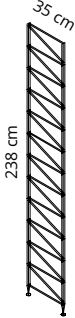

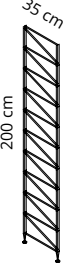



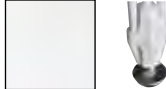

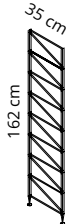
# BIBLIOTECH











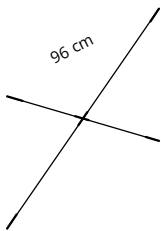

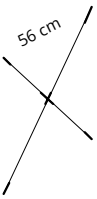

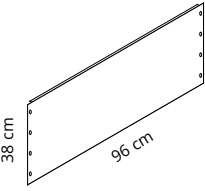

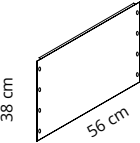













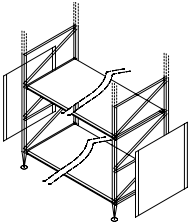
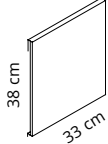

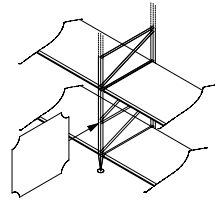
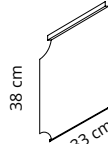
**Caimi**

# 2 SOCRATE Profondità / Depth 35











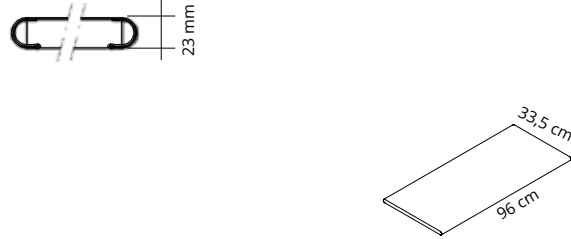
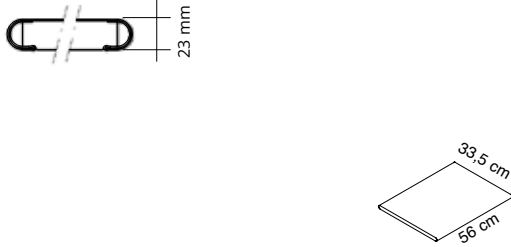



Caimi

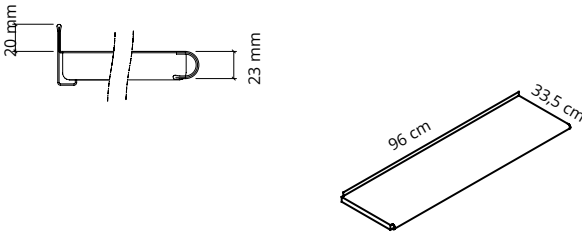
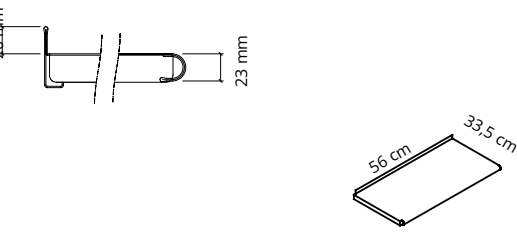



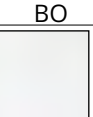

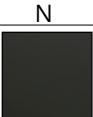

	 			 		
CD.	3400-BO	3400-GM	3400-N	3200-BO	3200-GM	3200-N
CL.	BO	GM	N	BO	GM	N
DS.						
	<p>Montanti in tondino di acciaio elettrosaldato verniciato con polveri epossidiche - <b>Tappini e piedini inclusi.</b>            Powder-coated electrowelded steel rod side uprights - <b>Feet and caps included.</b>            Montants en rond d'acier électrosoudé peint en époxy - <b>Taquets et pieds inclus.</b>            Laterales en acero barnizado con polvos epoxídicos - <b>Tapas y patas incluidas.</b>            Seitenteile aus elektrogelötetem Stahlrohr, mit Epoxypulver beschichtet. <b>Abdeckkappen und Füße inklusive.</b></p>					
	 			 		
CD.	3600-BO	3600-GM	3600-N	3800-BO	3800-GM	3800-N
CL.	BO	GM	N	BO	GM	N
DS.						
	<p>Montanti in tondino di acciaio elettrosaldato verniciato con polveri epossidiche - <b>Tappini e piedini inclusi.</b>            Powder-coated electrowelded steel rod side uprights - <b>Feet and caps included.</b>            Montants en rond d'acier électrosoudé peint en époxy - <b>Taquets et pieds inclus.</b>            Laterales en acero barnizado con polvos epoxídicos - <b>Tapas y patas incluidas.</b>            Seitenteile aus elektrogelötetem Stahlrohr, mit Epoxypulver beschichtet. <b>Abdeckkappen und Füße inklusive.</b></p>					

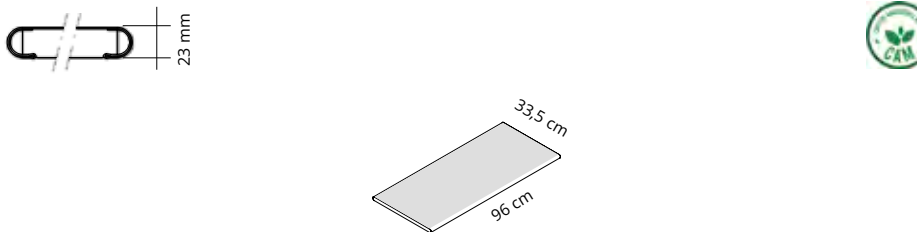
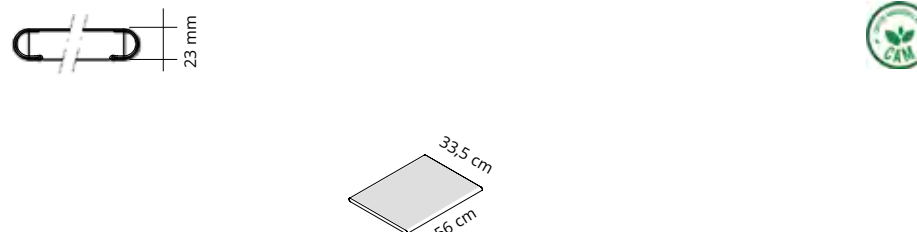
	 			 			 			 		
<b>CD.</b>	<b>2910-BO</b>	<b>2910-GM</b>	<b>2910-N</b>	<b>2960-BO</b>	<b>2960-GM</b>	<b>2960-N</b>	<b>2712-BO</b>	<b>2712-GM</b>	<b>2712-N</b>	<b>2715-BO</b>	<b>2715-GM</b>	<b>2715-N</b>
<b>CL.</b>	BO	GM	N	BO	GM	N	BO	GM	N	BO	GM	N
												
<b>DS.</b>	<p>Crociere in tondino di acciaio verniciato con polveri epossidiche.                      Powder-coated steel rod bracing crosses.                      Croisillons en rond d'acier peint en époxy.                      Soportes traseros en acero barnizado con polvos epoxídicos.                      Stabilisierungskreuze aus mit Epoxypulver beschichtetem Stahl.</p>						<p>Schienali in lamiera verniciata.                      Powder-coated steel back panel.                      Panneaux postérieurs en acier peint.                      Traseras en acero barnizado.                      Rückwände aus pulverbeschichtetem Stahl.</p>					
	  						  					
<b>CD.</b>	<b>2625-BO</b>		<b>2625-GM</b>			<b>2625-N</b>	<b>2738-BO</b>		<b>2738-GM</b>		<b>2738-N</b>	
<b>CL.</b>	BO		GM			N	BO		GM		N	
												
<b>DS.</b>	<p>Chiusure esterne in acciaio.                      Steel external closings.                      Fermetures externes en acier.                      Cierres externas en acero.                      Außenverkleidungen aus Stahl.</p>						<p>Chiusure interne in acciaio.                      Steel internal closing elements.                      Fermetures internes en acier.                      Cierres internas en acero.                      Innenverkleidungen aus Stahl.</p>					

# 4 SOCRATE Profondità / Depth 35

Caimi

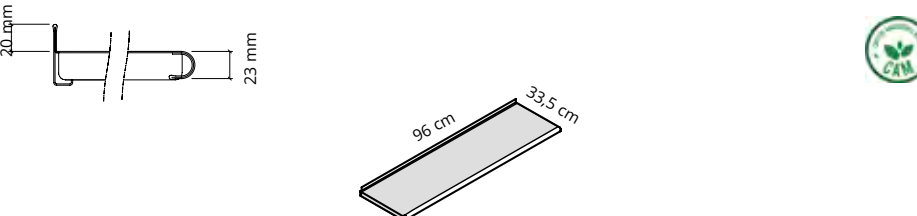
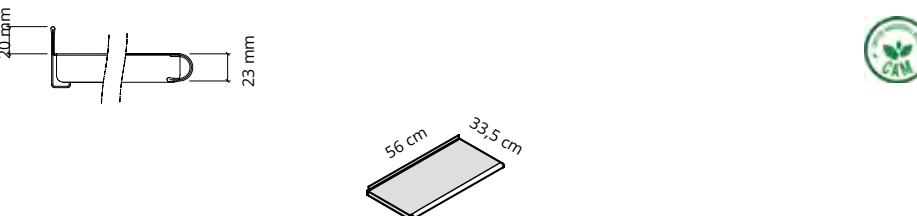
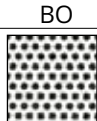
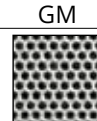
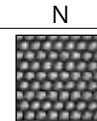
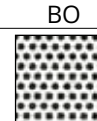
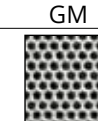
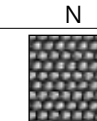
					
<p>CD. <b>3012-BO</b></p>	<p><b>3012-GM</b></p>	<p><b>3012-N</b></p>	<p><b>3062-BO</b></p>	<p><b>3062-GM</b></p>	<p><b>3062-N</b></p>
<p>CL. BO</p> 	<p>GM</p> 	<p>N</p> 	<p>BO</p> 	<p>GM</p> 	<p>N</p> 
<p>DS. Ripiani in acciaio verniciato con polveri epossidiche, spessore 23 mm.          Powder-coated steel shelves, 23mm thick.          Tablettes en acier peint en époxy, épaisseur 23 mm.          Estantes en acero barnizado con polvos epoxídicos, espesor 23 mm.          Regalböden aus Epoxypulver beschichtetem Stahlblech, Stärke 23 mm.</p>					
					
<p>CD. <b>63012-BO</b></p>	<p><b>63012-GM</b></p>	<p><b>63012-N</b></p>	<p><b>63062-BO</b></p>	<p><b>63062-GM</b></p>	<p><b>63062-N</b></p>
<p>CL. BO</p> 	<p>GM</p> 	<p>N</p> 	<p>BO</p> 	<p>GM</p> 	<p>N</p> 
<p>DS. Ripiani in acciaio verniciato con polveri epossidiche. I ripiani possono essere montati dritti o inclinati.          Powder-coated steel shelves. The shelves can be assembled straight or inclined.          Tablettes en acier peint en époxy. Les tablettes peuvent être montées soit à plat ou inclinées.          Estantes en acero barnizado con polvos epoxídicos. Los estantes se pueden colocar rectos o inclinados.          Regalböden aus Epoxypulver beschichtetem Stahlblech. Die Regalböden können schräg oder gerade montiert werden.</p>			<p>Dettaglio reggilibri  <b>OPZIONALE</b>          Detail of book holder  <b>OPTIONAL</b>          vedi pag. / see page 159</p> 		

					
<p>CD. <b>3010-BO</b></p>	<p><b>3010-GM</b></p>	<p><b>3010-N</b></p>	<p><b>3060-BO</b></p>	<p><b>3060-GM</b></p>	<p><b>3060-N</b></p>
<p>CL. BO</p> 	<p>GM</p> 	<p>N</p> 	<p>BO</p> 	<p>GM</p> 	<p>N</p> 
<p>DS. Ripiani in acciaio microforato verniciato con polveri epossidiche, spessore 23 mm.          Powder-coated micro-perforated steel shelves, 23mm thick.          Tablettes en acier microperforé peint en époxy, épaisseur 23 mm.          Estantes en acero microperforado barnizado con polvos epoxidicos, espesor 23 mm.          Regalböden aus gelochtem, mit Epoxypulver beschichtetem Stahlblech, Stärke 23 mm.</p>					
					
<p>CD. <b>63010-BO</b></p>	<p><b>63010-GM</b></p>	<p><b>63010-N</b></p>	<p><b>63060-BO</b></p>	<p><b>63060-GM</b></p>	<p><b>63060-N</b></p>
<p>CL. BO</p> 	<p>GM</p> 	<p>N</p> 	<p>BO</p> 	<p>GM</p> 	<p>N</p> 
<p>DS. Ripiani in acciaio microforato verniciato con polveri epossidiche. I ripiani possono essere montati dritti o inclinati.          Powder-coated micro-perforated steel shelves. The shelves can be assembled straight or inclined.          Tablettes en acier microperforé peint en époxy. Les tablettes peuvent être montées soit à plat ou inclinées.          Estantes en acero microperforado barnizado con polvos epoxidicos. Los estantes se pueden colocar rectos o inclinados.          Regalböden aus gelochtem, mit Epoxypulver beschichtetem Stahlblech. Die Regalböden können schräg oder gerade montiert werden.</p>			<p>Dettaglio reggilibri  <b>OPZIONALE</b>          Detail of book holder  <b>OPTIONAL</b>          vedi pag. / see page 159</p> 		

# 6 SOCRATE Profondità / Depth 35

Caimi

CD.	<b>3910-BO</b>	<b>3910-GM</b>	<b>3910-N</b>	<b>3960-BO</b>	<b>3960-GM</b>	<b>3960-N</b>
CL.	BO	GM	N	BO	GM	N
DS.	<p>Ripiani espositori inclinati in acciaio microforato verniciato con polveri epossidiche.                      Inclined display shelves in powder-coated micro-perforated steel.                      Tablettes/présentoirs inclinés en acier microperforé peint en époxy.                      Estantes expositores inclinados en acero microperforado barnizado con polvos epoxidicos.                      Schrägtablare aus gelochtem, mit Epoxypulver beschichtetem Stahl</p>					
CD.	<p>Solo per ripiani art:                      Only for shelves code:                      Seulement pour tablettes réf:                      Solo para estantes ref:                      Nur für Regalböden Art:                      3010, 3012, 63010, 63012</p>					
	<p><b>2679</b></p>					
CL.						
DS.	<p>Espositore/emerooteca in metacrilato traslucido a tre ante, supporti in acciaio grigio metallizzato.                      Display/magazine rack with 3 flap panels in translucent methacrylate, metal grey steel supports.                      Présentoir à revues à 3 volets en méthacrilate translucide, supports en acier gris métallisé.                      Expositor en metacrilato translúcido a tres puertas, soportes en acero barnizado gris metalizado.                      Magazinasusteller mit 3 Klappen aus durchsichtigem Methacrylat, Träger aus Stahl, grau metallic.</p>					



Da ordinare a multipli di 10 pezzi.  
To be ordered in multiples of 10 pieces.  
A commander par multiple de 10 pièces.  
A pedirse en múltiplos de 10 piezas.  
Verpackungseinheit 10 Stück.

Per art.:  
For ref.:  
Pour réf.:  
Para ref.:  
Für Art.:  
63010, 63060  
63012, 63062



**6A2780**

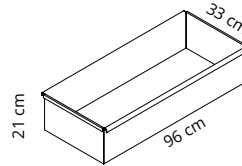



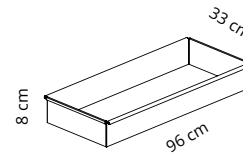







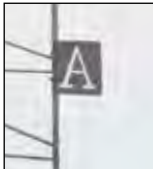



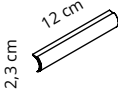





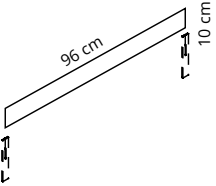
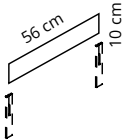
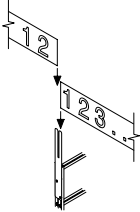

<b>CD.</b>	<b>3510-BO</b>	<b>3510-GM</b>	<b>3510-N</b>	
<b>CL.</b>	BO	GM	N	C
<b>DS.</b>	Contenitore in acciaio verniciato. Case in powder-coated steel. Bac en acier peint. Recipiente en acero barnizado. Behälter aus pulverbeschichtetem Stahl.			Reggilibro in acciaio cromato. Chrome-plated steel book holder. Serre-livres en acier chromé. Separadores en acero cromado. Buchstütze aus verchromtem Stahl.











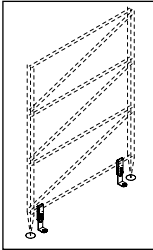

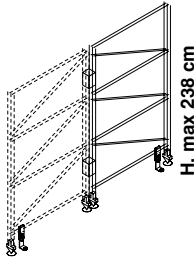

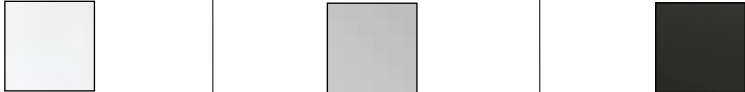



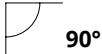

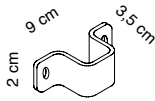
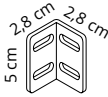
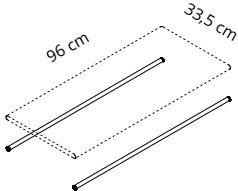

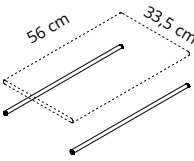







<b>CD.</b>	<b>3512-BO</b>	<b>3512-GM</b>	<b>3512-N</b>	
<b>CL.</b>	BO	GM	N	
<b>DS.</b>	Contenitore in acciaio verniciato. Case in powder-coated steel. Bac en acier peint. Recipiente en acero barnizado. Behälter aus pulverbeschichtetem Stahl.			















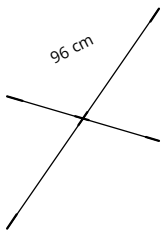
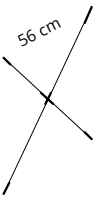
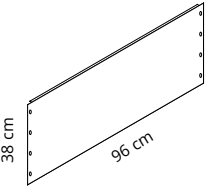
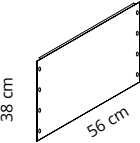







# 8 SOCRATE Profondità / Depth 35

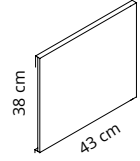
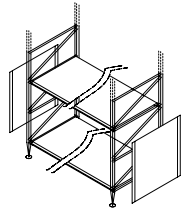
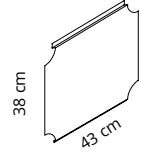
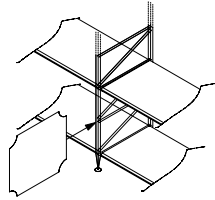



Caimi

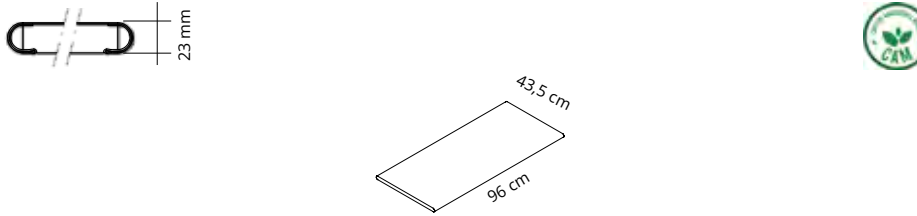
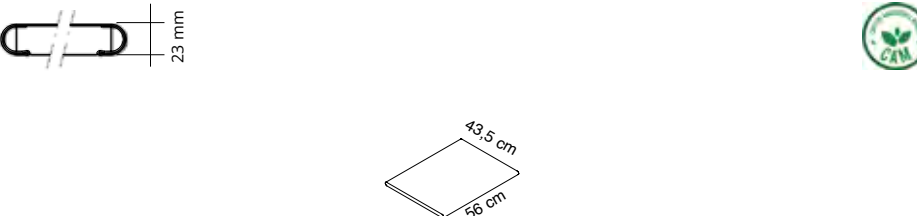

	 						<p>Per ripiani art: For shelves code: Pour tablettes réf: Para estantes ref: Für Regalböden Art: 3010, 3060, 3012, 3062, 3910, 3960 63010, 63060, 63012, 63062</p>   		
CD.	2746-BO		2746-GM		2746-N	6A52			
CL.	BO		GM		N	T			
									
DS.	<p>Bandiera segnaletica in acciaio verniciato. Powder-coated steel sign banner. Bande signalétique en acier peint. Placa de señalización en acero barnizado. Beschriftungsschild aus pulverbeschichtetem Stahl.</p>					<p>Segnaletica per ripiani con bordo tondo. Sign system for round edge shelves. Signalisation pour tablettes avec bord rond. Señalización para estantes borde redondo. Beschilderung für Tablare mit abgerundeter Kante.</p>			
	    						<p>Per art: For ref.: Pour réf.: Para ref.: Für Art.: 6A2272, 6A2274</p>   		
CD.	6A2272 (BO)	6A2272 (GM)	6A2272 (N)	6A2274 (BO)	6A2274 (GM)	6A2274 (N)	6A2278 (BO)	6A2278 (GM)	6A2278 (N)
CL.	BO	GM	N	BO	GM	N	BO	GM	N
									
DS.	<p>Fascioni segnaletici in acciaio verniciato. Powder-coated steel sign bands. Panneaux signalétiques en acier peint. Bandas de señalización en acero barnizado. Beschriftungspaneele aus pulverbeschichtetem Stahl.</p>						<p>Supporti fascione segnaletico. Supports for sign bands. Supports pour panneaux signalétiques. Soportes para bandas de señalización. Halierung für Beschriftungspaneele.</p>		

  	 
<p>CD. <b>2646-BO</b> <b>2646-GM</b> <b>2646-N</b></p>	<p>CD. <b>2995/46-BO</b> <b>2995/46-GM</b> <b>2995/46-N</b></p>
<p>CL. BO GM N</p> 	<p>CL. BO GM N</p> 
<p>DS. Coppia staffe per fissaggio a terra dei montanti. Da utilizzare in caso di moduli non fissati a parete.          Couple of brackets for side uprights fixing to the floor. To be used only for modules not attached to the wall.          Paire d'étriers de fixation au sol pour montants. A utiliser pour modules qui ne sont pas fixés au mur.          2 fijación al suelo para laterales. Para ser usados solamente en el caso de los módulos no fijados a la pared.          Ein Paar Halterungen zur Befestigung der Seitensteher am Boden. Nur zur Verwendung bei Elementen, welche nicht an der Wand befestigt werden.</p>	<p>2 giunti trasparenti per unione bifronte e 2 staffe per fissaggio a terra dei montanti.          2 transparent joints for double-sided connection + 2 brackets to fix uprights to the floor.          2 joints transparents pour accouplement bifrontal et 2 étrier fixation au sol pour montants.          2 juntas transparentes para conexión bifrontal y 2 fijación al suelo para laterales.          2 Doppelseitige Module und 2 Klammer zur Bodenbefestigung von Seitenteilen.</p>
      	<p>Per art. / For ref. / Pour réf. / Para ref. / Für Art.  <b>3010, 3012, 63010, 63012</b>          ATTENZIONE:          1 3973-GM per/for 1 code 3010, 3012          1 3973-GM per/for 2 code 63010, 63012</p>   <p>Per art. / For ref. / Pour réf. / Para ref. / Für Art.  <b>3060, 3062, 63060, 63062</b>          ATTENZIONE:          1 3974-GM per/for 1 code 3060, 3062          1 3974-GM per/for 2 code 63060, 63062</p>  
<p>CD. <b>4994-GM</b> <b>4994-BO</b> <b>2996-GM</b></p>	<p>CD. <b>3973-GM</b> <b>3974-GM</b></p>
<p>CL. GM BO GM</p> 	<p>CL. GM GM</p> 
<p>DS. Staffa per fissaggio a parete dei montanti.          Steel bracket used to fix side upright to wall.          Etrier de fixation au mur pour montants.          Fijación a pared para laterales.          Klammer für Wandbefestigung der Seitenteile.</p>	<p>Coppia di squadrette per unione montanti a 90°.          Pair of joints for 90° side uprights connection.          Paire de joints pour union montants à 90°.          Par de juntas para conexión de laterales a 90°.          2 Beschläge für Seitenteileckkombinationen 90°.</p> <p>2 rinforzi in acciaio verniciato per ripiani Top posizionati ad altezza 100 cm o inferiore.          2 strengthenings for top shelves on units 100 cm high or lower.          2 renforcements tablette dessus, pour modules en hauteur 100 cm ou inférieure.          2 refuerzos para estante superior situado a una altura de 100 cm o inferior.          2 Verstärkung für oberen Regalböden bei einer Regalhöhe von 100 cm oder niedriger.</p>

<p>CD.</p>	 	 
	<p><b>4200-BO</b></p>	<p><b>4600-BO</b></p>
<p>CL.</p>	<p><b>4200-GM</b></p>	<p><b>4600-GM</b></p>
<p>DS.</p>	<p>BO</p> 	<p>GM</p> 
	<p>Montanti in tondino di acciaio elettrosaldato verniciato con polveri epossidiche - <b>Tappini e piedini inclusi.</b>          Powder-coated electrowelded steel rod side uprights - <b>Feet and caps included.</b>          Montants en rond d'acier électrosoudé peint en époxy - <b>Taquets et pieds inclus.</b>          Laterales en acero barnizado con polvos epoxídicos - <b>Tapas y patas incluidas.</b>          Seitenteile aus elektrogelötetem Stahlrohr, mit Epoxypulver beschichtet. <b>Abdeckkappen und Füße inklusive.</b></p>	
<p>CD.</p>	 	 
	<p><b>4800-BO</b></p>	<p><b>4800-GM</b></p>
<p>CL.</p>	<p>BO</p>	<p>GM</p>
<p>DS.</p>		
	<p>Montanti in tondino di acciaio elettrosaldato verniciato con polveri epossidiche - <b>Tappini e piedini inclusi.</b>          Powder-coated electrowelded steel rod side uprights - <b>Feet and caps included.</b>          Montants en rond d'acier électrosoudé peint en époxy - <b>Taquets et pieds inclus.</b>          Laterales en acero barnizado con polvos epoxídicos - <b>Tapas y patas incluidas.</b>          Seitenteile aus elektrogelötetem Stahlrohr, mit Epoxypulver beschichtet. <b>Abdeckkappen und Füße inklusive.</b></p>	



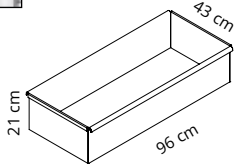

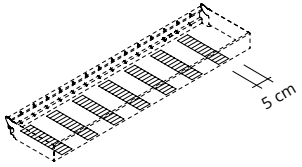

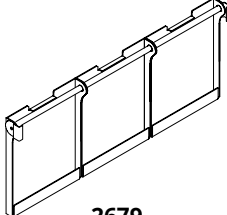

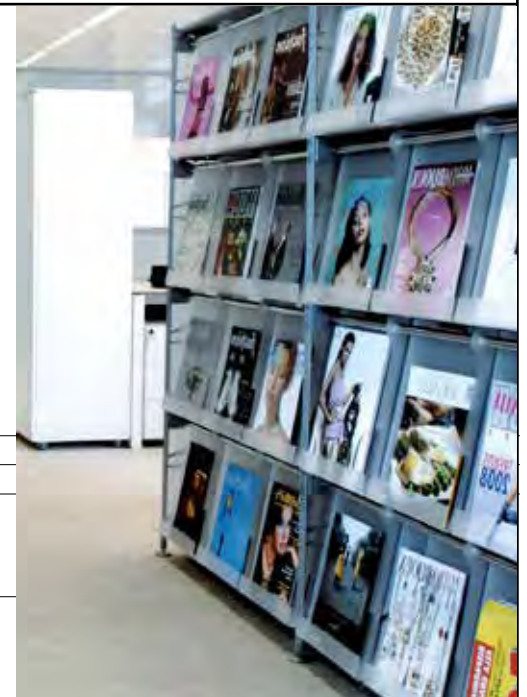



								
								
<b>CD.</b>	<b>2910-BO      2910-GM</b>		<b>2960-BO      2960-GM</b>		<b>2712-BO      2712-GM</b>		<b>2715-BO      2715-GM</b>	
<b>CL.</b>	BO	GM	BO	GM	BO	GM	BO	GM
								
<b>DS.</b>	<p>Crociere in tondino di acciaio verniciato con polveri epossidiche.                  Powder-coated steel rod bracing crosses.                  Croisillons en rond d'acier peint en époxy.                  Soportes traseros en acero barnizado con polvos epoxídicos.                  Stabilisierungskreuze aus mit Epoxypulver beschichtetem Stahl.</p>				<p>Schienen in lamiera verniciata.                  Powder-coated steel back panel.                  Panneaux postérieurs en acier peint.                  Traseras en acero barnizado.                  Rückwände aus pulverbeschichtetem Stahl.</p>			
								
								
<b>CD.</b>	<b>2612-BO</b>		<b>2612-GM</b>		<b>2735-BO</b>		<b>2735-GM</b>	
<b>CL.</b>	BO	GM	BO	GM	BO	GM	BO	GM
								
<b>DS.</b>	<p>Chiusure esterne in acciaio.                  Steel external closings.                  Fermetures externes en acier.                  Cierres externas en acero.                  Außenverkleidungen aus Stahl.</p>				<p>Chiusure interne in acciaio.                  Steel internal closing elements.                  Fermetures internes en acier.                  Cierres internas en acero.                  Innenverkleidungen aus Stahl.</p>			

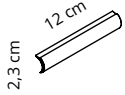

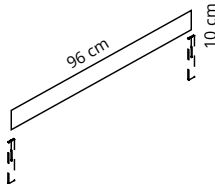
			
<p><b>CD.</b> <b>4012-GM</b></p>	<p><b>4012-BO</b></p>	<p><b>4062-GM</b></p>	<p><b>4062-BO</b></p>
<p><b>CL.</b> GM</p> 	<p>BO</p> 	<p>GM</p> 	<p>BO</p> 
<p><b>DS.</b> Ripiani in acciaio verniciato con polveri epossidiche, spessore 23 mm.          Powder-coated steel shelves, 23mm thick.          Tablettes en acier peint en époxy, épaisseur 23 mm.          Estantes en acero barnizado con polvos epoxidicos, espesor 23 mm.          Regalböden aus Epoxypulver beschichtetem Stahlblech, Stärke 23 mm.</p>			

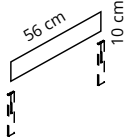

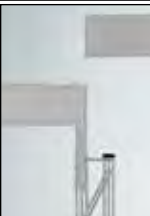
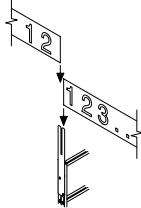
	 		 
<b>CD.</b>	<b>4110-GM</b>	<b>4110-BO</b>	<b>6A63</b>
<b>CL.</b>	GM	BO	N
<b>DS.</b>	<p>Contenitore in acciaio verniciato. Case in powder-coated steel. Bac en acier peint. Recipiente en acero barnizado. Behälter aus pulverbeschichtetem Stahl.</p>		<p>Strisce adesive antiderapanti per art. <b>4110</b> Adhesive antislip strips for code <b>4110</b> Fonds adhésives antidérapants pour réf. <b>4110</b> Ffondos antideslizantes adhesivos para ref. <b>4110</b> Selbstklebende Gleitschutzstreifen für Art. <b>4110</b></p>

<b>CD.</b>	<p><b>Solo per ripiani art:</b> <b>Only for shelves code:</b> <b>Seulement pour tablettes réf:</b> <b>Solo para estantes ref:</b> <b>Nur für Regalböden Art:</b> <b>4012</b></p>  
<b>CL.</b>	
<b>DS.</b>	<p>Espositore/emerooteca in metacrilato traslucido a tre ante, supporti in acciaio grigio metallizzato. Display/magazine rack with 3 flap panels in translucent methacrylate, metal grey steel supports. Présentoir à revues à 3 volets en méthacrylate translucide, supports en acier gris métallisé. Expositor en metacrilato traslúcido a tres puertas, soportes en acero barnizado gris metalizado. Magazinaussteller mit 3 Klappen aus durchsichtigem Methacrylat, Träger aus Stahl, grau metallic.</p>

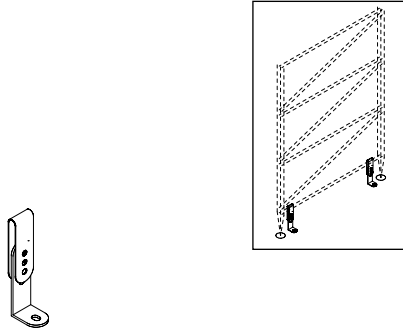
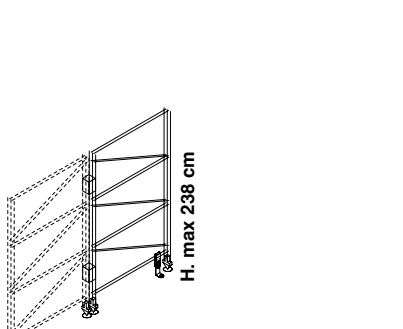
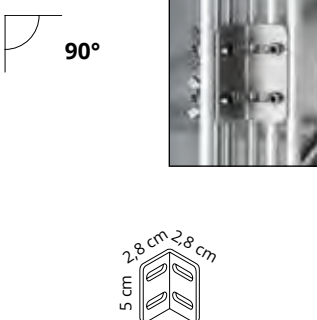
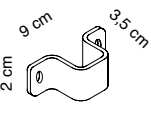

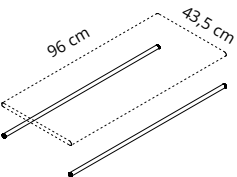
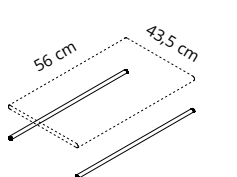
<p>CD.</p>	  <p><b>2746-BO</b></p>	 <p><b>2746-GM</b></p>	<p>Per ripiani art: For shelves code: Pour tablettes réf: Para estantes ref: Für Regalböden Art: 4012, 4062</p>    <p><b>6A52</b></p>	
<p>CL.</p>	<p>BO</p>	<p>GM</p>	<p>T</p>	
<p>DS.</p>	<p>Bandiera segnaletica in acciaio verniciato. Powder-coated steel sign banner. Bande signalétique en acier peint. Placa de señalización en acero barnizado. Beschriftungsschild aus pulverbeschichtetem Stahl.</p>		<p>Segnaletica per ripiani con bordo tondo. Sign system for round edge shelves. Signalisation pour tablettes avec bord rond. Señalización para estantes borde redondo. Beschilderung für Tablare mit abgerundeter Kante.</p>	
<p>CD.</p>	  <p><b>6A2272 (BO)</b></p>	  <p><b>6A2272 (GM)</b></p>	  <p><b>6A2274 (BO)</b>      <b>6A2274 (GM)</b></p>	<p>Per art.: For ref.: Pour réf.: Para ref.: Für Art.: 6A2272, 6A2274</p>   <p><b>6A2278 (BO)</b></p>  <p><b>6A2278 (GM)</b></p>
<p>CL.</p>	<p>BO</p>	<p>GM</p>	<p>BO      GM</p>	<p>BO      GM</p>
<p>DS.</p>	<p>Fascioni segnaletici in acciaio verniciato. Powder-coated steel sign bands. Panneaux signalétiques en acier peint. Bandas de señalización en acero barnizado. Beschriftungspaneele aus pulverbeschichtetem Stahl.</p>		<p>Supporti fascione segnaletico. Supports for sign bands. Supports pour panneaux signalétiques. Soportes para bandas de señalización. Halterung für Beschriftungspaneele.</p>	

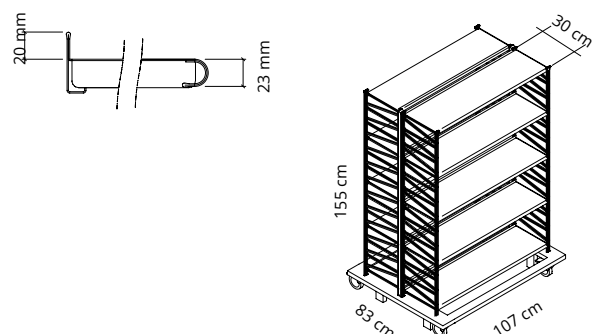
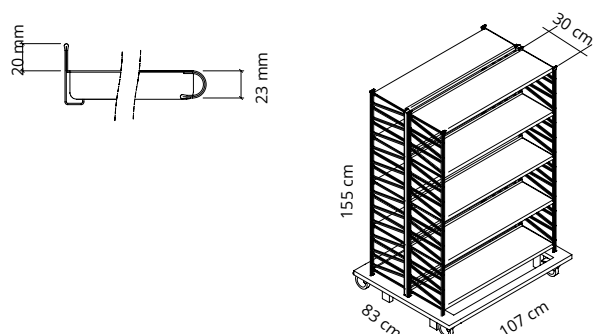
 <p><b>CD.</b> <b>2646-GM</b> <b>2646-BO</b></p>	 <p><b>CD.</b> <b>2995/46-GM</b> <b>2995/46-BO</b></p>			
<p><b>CL.</b> GM BO</p>	<p><b>CL.</b> GM BO</p>			
<p><b>DS.</b> Coppia staffe per fissaggio a terra dei montanti. Da utilizzare in caso di moduli non fissati a parete. Couple of brackets for side uprights fixing to the floor. To be used only for modules not attached to the wall. Paire d'étriers de fixation au sol pour montants. A utiliser pour modules qui ne sont pas fixés au mur. 2 fijación al suelo para laterales. Para ser usados solamente en el caso de los módulos no fijados a la pared. Ein Paar Halterungen zur Befestigung der Seitensteher am Boden. Nur zur Verwendung bei Elementen, welche nicht an der Wand befestigt werden.</p>	<p><b>DS.</b> 2 giunti trasparenti per unione bifronte e 2 staffe per fissaggio a terra dei montanti. 2 transparent joints for double-sided connection + 2 brackets to fix uprights to the floor. 2 joints transparents pour accouplement bifrontal et 2 étrier fixation au sol pour montants. 2 juntas transparentes para conexión bifrontal y 2 fijación al suelo para laterales. 2 Doppelseitige Module und 2 Klammer zur Bodenbefestigung von Seitenteilen.</p>			
 <p><b>CD.</b> <b>2996-GM</b></p>	 <p><b>CD.</b> <b>4994-GM</b></p>	 <p><b>CD.</b> <b>4994-BO</b></p>	<p>Per art. / For ref. / Pour réf. / Para ref. / Für Art. 4012 ATTENZIONE: 1 3973-GM per/for 1 code 4012</p>  <p><b>CD.</b> <b>3973-GM</b></p>	<p>Per art. / For ref. / Pour réf. / Para ref. / Für Art. 4062 ATTENZIONE: 1 3974-GM per/for 1 code 4062</p>  <p><b>CD.</b> <b>3974-GM</b></p>
<p><b>CL.</b> GM</p>	<p><b>CL.</b> GM</p>	<p><b>CL.</b> BO</p>	<p><b>CL.</b> GM</p>	<p><b>CL.</b> GM</p>
<p><b>DS.</b> Coppia di squadrette per unione montanti a 90°. Pair of joints for 90° side uprights connection. Paire de joints pour union montants à 90°. Par de juntas para conexión de laterales a 90°. 2 Beschläge für Seitenteileckkombinationen 90°.</p>	<p><b>DS.</b> Staffa per fissaggio a parete dei montanti. Steel bracket used to fix side upright to wall. Etrier de fixation au mur pour montants. Fijación a pared para laterales. Klammer für Wandbefestigung der Seitenteile.</p>	<p><b>DS.</b> 2 rinforzi in acciaio verniciato per ripiani Top posizionati ad altezza 100 cm o inferiore. 2 strengthenings for top shelves on units 100 cm high or lower. 2 renforcements tablette dessus, pour modules en hauteur 100 cm ou inférieure. 2 refuerzos para estante superior situado a una altura de 100 cm o inferior. 2 Verstärkung für oberen Regalböden bei einer Regalhöhe von 100 cm oder niedriger.</p>	<p><b>DS.</b> 2 rinforzi in acciaio verniciato per ripiani Top posizionati ad altezza 100 cm o inferiore. 2 strengthenings for top shelves on units 100 cm high or lower. 2 renforcements tablette dessus, pour modules en hauteur 100 cm ou inférieure. 2 refuerzos para estante superior situado a una altura de 100 cm o inferior. 2 Verstärkung für oberen Regalböden bei einer Regalhöhe von 100 cm oder niedriger.</p>	<p><b>DS.</b> 2 rinforzi in acciaio verniciato per ripiani Top posizionati ad altezza 100 cm o inferiore. 2 strengthenings for top shelves on units 100 cm high or lower. 2 renforcements tablette dessus, pour modules en hauteur 100 cm ou inférieure. 2 refuerzos para estante superior situado a una altura de 100 cm o inferior. 2 Verstärkung für oberen Regalböden bei einer Regalhöhe von 100 cm oder niedriger.</p>

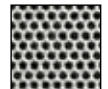
 <p><b>6A2102 (GM)</b></p>	 <p><b>6A2100 (GM)</b></p>
<p>CD.</p>	<p>CD.</p>
<p>CL.</p> <p>GM</p> 	<p>CL.</p> <p>GM</p> 
<p>DS.</p> <p>Libreria/espositore bifronte su ruote con 10 ripiani in acciaio pieno. I ripiani possono essere montati dritti o inclinati.          Double-sided shelving/display unit on castors, with 10 plain steel shelves. The shelves can be assembled straight or inclined.          Rayonnage/présentoir double-face sur roulettes, avec 10 tablettes en acier plein. Les tablettes peuvent être montées soit à plat ou inclinées.          Libreria/expositor a dos caras con ruedas y 10 estantes en acero sólido. Los estantes se pueden colocar rectos o inclinados.          Doppelseitiges Regal/Aussteller auf Rollen mit 10 Regalböden aus Stahlblech. Die Regalböden können schräg oder gerade montiert werden.</p>	<p>DS.</p> <p>Libreria/espositore bifronte su ruote con 10 ripiani in acciaio microforato. I ripiani possono essere montati dritti o inclinati.          Double-sided shelving/display unit on castors, with 10 micro-perforated steel shelves. The shelves can be assembled straight or inclined.          Rayonnage/présentoir double-face sur roulettes, avec 10 tablettes en acier microperforé. Les tablettes peuvent être montées soit à plat ou inclinées.          Libreria/expositor a dos caras con ruedas y 10 estantes en acero microperforado. Los estantes se pueden colocar rectos o inclinados.          Doppelseitiges Regal/Aussteller auf Rollen mit 10 Regalböden aus gelochtem Stahlblech. Die Regalböden können schräg oder gerade montiert werden.</p>

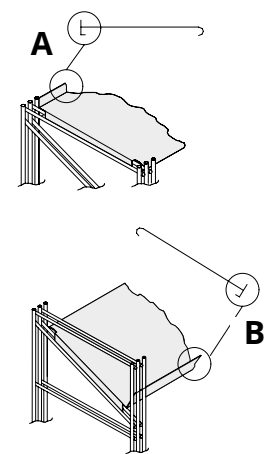

I ripiani possono essere montati dritti o inclinati.  
 The shelves can be assembled straight or inclined.  
 Les tablettes peuvent être montées soit à plat ou inclinées.  
 Los estantes se pueden colocar rectos o inclinados.  
 Die Regalböden können schräg oder gerade montiert werden.

		MIN.	MAX.	MIN.	MAX.
		1	3	3	6
		MIN.	MAX.	MIN.	MAX.
		1	2	2	5
		MIN.	MAX.	MIN.	MAX.
		1	2	2	4
		MIN.	MAX.	MIN.	MAX.
		1	1	1	2

H 238

H 200

H 162

H 86

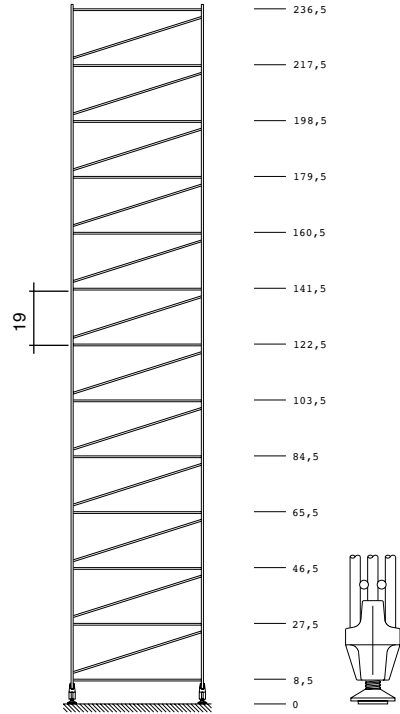

Numero minino e massimo di elementi per modulo completo.  
 Minimum and maximum number of load bearing elements for a complete module.  
 Nombre minimum et maximum d' éléments de soutien nécessaires pour un module complet.  
 Numero maximo y minimo de elementos de carga para un modulo completo.  
 Minimale und maximale Anzahl von benötigten Stabilisierungsteilen.

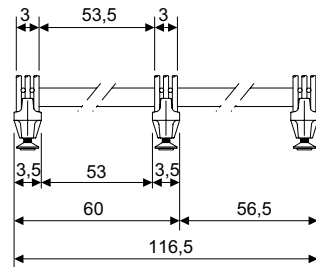
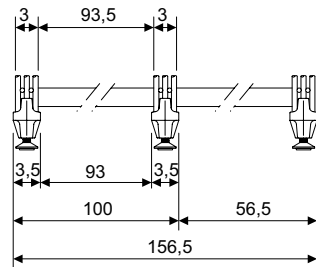
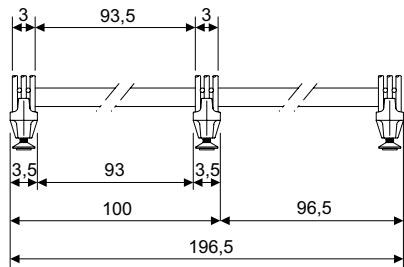
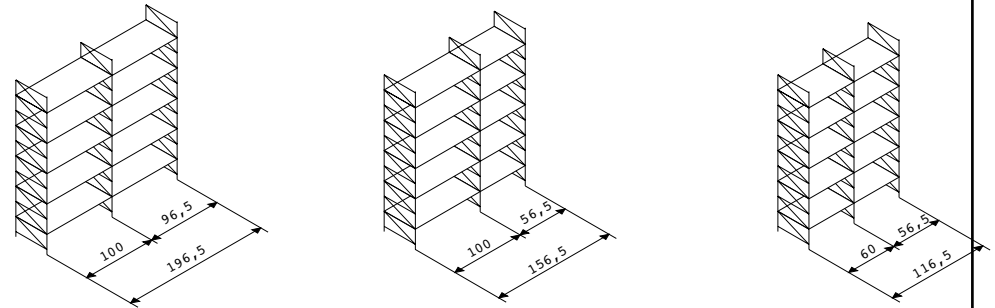

Dimensioni in cm - Dimensions in cm - Dimensions en cm - Dimensiones en cm - Dimensionen in cm

Deze informatie is afkomstig van de website van Zero-Z design.

Voor vragen, toelichting en meer informatie kunt u contact opnemen met:

**Zero-Z design**

Modem 20b

7741 MJ Coevorden

**T** +31 (0)30 2201297

**E** [info@zero-z-design.nl](mailto:info@zero-z-design.nl)

**W** [www.zero-z-design.nl](http://www.zero-z-design.nl)

[www.akoestiekexpert.nl](http://www.akoestiekexpert.nl)

